

Sponsor Handbook



2022-23

By emphasizing rigorous engineering, technical expertise, and effective management, MIT Motorsports empowers students to become engineering leaders.

Why We're Here

The Competition

The Formula SAE competition tasks students to design, build, and engineer a racecar. Starting from the ground up, each team constructs a vehicle that is judged on design, cost, business case, and performance.

Formula SAE pushes students to apply their classroom knowledge to a real world project. The process prepares students to engineer in many fields, as the project has applications ranging across automotive, aerospace, mechanical, business, and data industries.

Our Mission Statement

MIT Motorsports strives to provide students with the best means to learn about the engineering process - by emphasizing rigorous engineering, strong technical expertise, and effective management.



Team Statistics

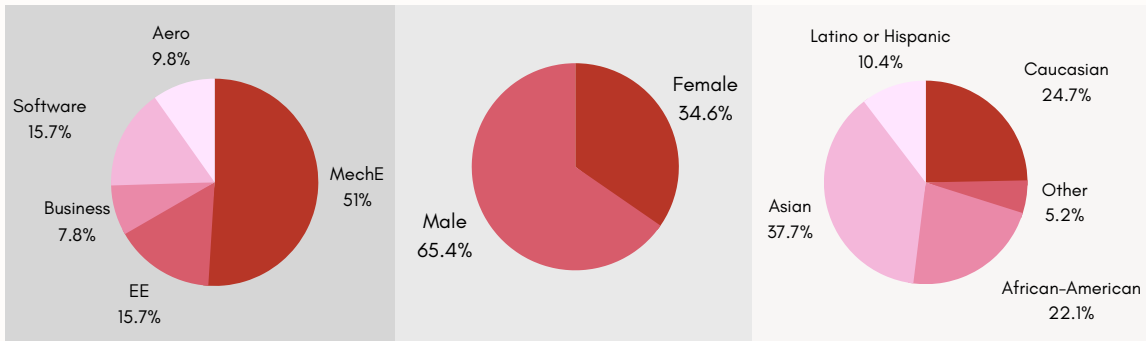

Meet Our Executive Board

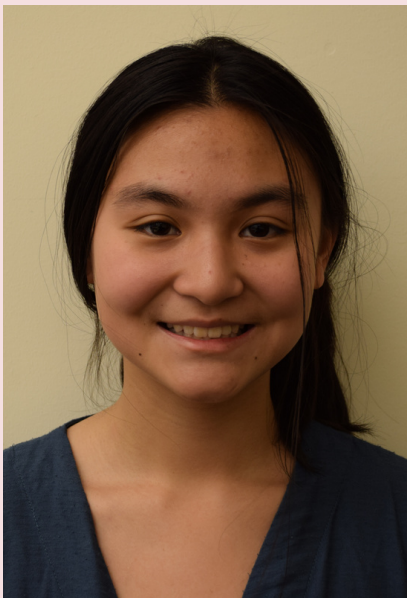

Megan Gupta-She

Captain
Business Lead



Alexis Huynh

Mechanical Lead



Alexandre Studer

Electrical Lead

Vision

Our team has faced challenges in the last year, but we are determined to come back stronger. In Model Year '23, we will lay down a strong foundation for future years to build on. After the instability of COVID, we hope to call on our established network for support.

Mission

01 Design

After establishing our team goals, we justify system level requirements using self-developed simulation tools. Next, our design shifts to developing vehicle components and creating a full-car computer model.

02 Design Reviews

Through the design cycle, design reviews offer a formal opportunity for input from peers, alumni, and involved sponsors. These reviews keep us on track and present learning opportunities for newer members.

03 Manufacturing

Our car is built in house from the ground up. Team members machine precision components in MIT's Edgerton Center facilities, teaching them to tread the line between innovative geometry optimization and practical, manufacturable designs.

04 Testing

We place high emphasis on testing, aiming to spend just as much time on testing as design. To build a robust and reliable electric vehicle, we go on weekly testing trips, honing our vehicle's performance, controls and training our drivers.

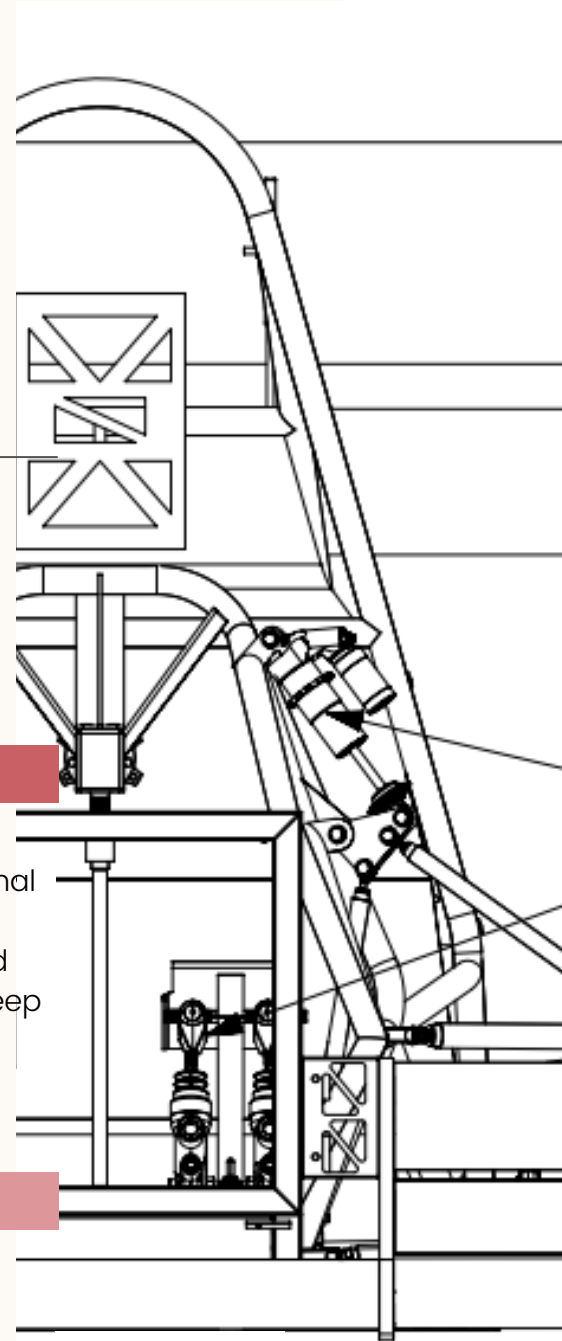

Evolution of MIT Motorsports

2001

FOUNDING

MIT Motorsports first entered the Formula SAE scene when two freshmen founded the team. Since our 97th place finish at the first competition in 2003, MIT Motorsports has been a nonstop adventure.



2012

STRATEGY SHIFT

The two year cycle from 2012-2013 was the end of an era: the last time that MIT Motorsports used a combustion engine. After an 8th place finish in 2011 and top 5 fuel economy and cost finishes in 2012, the team left gas in style.



2015

TRANSITION TO EV

MY15 was the team's first completed running electric vehicle (EV). A working car meant the team could test the powertrain and acquire data. It also had the first aerodynamics package in team history.



2017

RECORD SUCCESS

MY17's second place finish showcased how far we've come. The aero package that increased downforce by 300%, custom battery, new wheel package design, and other improvements helped push the team to a new level.



2021

TOUGH CHALLENGE

Out of only 20 registered teams, we were one of eight who passed battery inspection. Although COVID significantly impacted the FSAE community, MIT Motorsports displayed promising results and placed among the strongest competitive teams in the nation.



Looking Forward

Model Year 2023

Our objective is to build a healthy, confident, and experienced engineering community that is prepared to take on greater risks for the future. We will focus on enforcing efficient engineering practices, restructuring design reviews, improving cross-subteam literacy, and bonding to grow an ever stronger community.



Why Join Us?

- Visibility**
Your logo and branding will appear on our website, social media, team shirts, and race car.
- Recruiting**
You will have the opportunity to recruit experienced and skillful students from our team through recruitment events or our resume book.
- Engagement**
Plant the seed for the younger generations to grow and develop through design reviews, shop tours and sponsor events.

Sponsorship Opportunities

We Need Your Support

While the Institute provides us with laboratory space in the Edgerton Center, we rely on fundraising to support our activities. We welcome both cash and in-kind donation. Fair market value of materials and equipment will be used to determine the level of support. Interested in sponsoring for Model Year 2023? Please see sponsorship benefits below. Tax deductible gifts can also be given to both the MIT Motorsports Expendable and Endowed fund but don't include benefits, in compliance with federal guidelines. Reach out at fsae@mit.edu.

Budget Breakdown

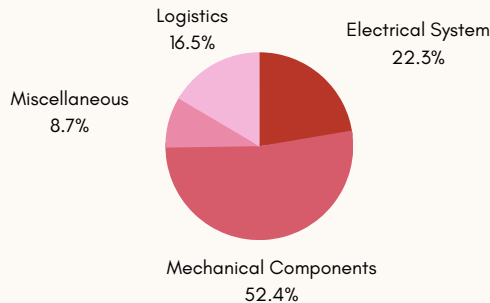

 Number of in-kind & monetary sponsors in MY22
30+ and growing

 Budget Projection
\$ 135 K

Sponsorship Tiers

	AFFILIATE \$100 - \$2,500	BRONZE \$2,500+	SILVER \$5,000+	GOLD \$10,000+	PLATINUM \$20,000+
INVITATION TO UNVEILING	✓	✓	✓	✓	✓
HONORED ON OUR WEBSITE	✓	✓	✓	✓	✓
LOGO ON TEAM APPAREL		✓	✓	✓	✓
LOGO ON CAR			SMALL	MEDIUM	LARGE
FEATURE ON OUR SOCIAL MEDIA				1X	3X
ACCESS TO RESUME BOOK				✓	✓
WEBSITE PROFILE					✓

Thank You

We hope to have your support!

MIT Motorsports thrives thanks to our community of student engineers, MIT support, corporate sponsors, and alumni. We would love for you to be part of our community.



Address

265 Massachusetts Ave, Cambridge, MA 02139



Telephone

+917-399-2765



Email

fsae@mit.edu



Thank you to our MY22 Sponsors!

Title	 MIT Edgerton Center
Platinum	Jim Cuseo Schlumberger  Nikhil Gidwani
Gold	  MITMECHE Joseph Donald Acar
Silver	Alex Soo   KISSsoft Christopher Graff   ALTUM DESIGNER SIEMENS   DHX machines
Bronze	 KX  Red Bull Bertucci's rapidHARNES Beantown TAQUERIA Café  FAST FORWARD COMPOSITES  actnano  MOOG SKF Richard James Hi-Temp Brazing David Otten
Affiliate	  Julia Kimberly David Proudfoot Andrew Kennett  James Otten and Catherine Smith